

Rotary cutter

TERADA

Crush the dry food ingredients thrown from the upper with the rotary blade and fixed blade. The particle size to be pulverized can be adjusted by selecting hole diameter of the screen.

Features

- Rotary blades are low rotation at 180 rpm, but good crushing is possible.
- It is durable and easy to handle.
- Screen and cover can be easily removed and cleaned.
- You can use the rotary blade and the fixed blade in 4 corners by changing the installation position.
- Magnet prevents magnetic metal contamination.
- There is no generation of dust, it is excellent in silence.
- The structure is simple.
- The SRC-2SUS uses sanitary stainless steel.

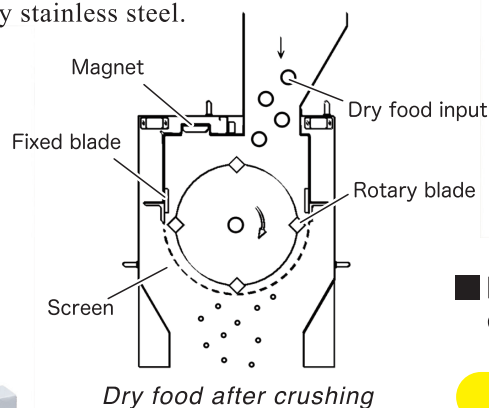

Processing example

sencha



tencha



dried bonito

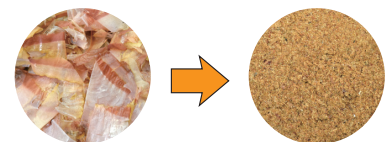

Specifications

Type	Width	Length	Height	Power (200V)	Weight (stand)	Capacity (using the φ5screen)
	mm	mm	mm	kW	kg	kg/h
SRC-2S	660	620	1,330	0.75	87	100 : green tea
SRC-2	660	620	1,330	0.75	84	100 : green tea

※Part of the specifications might be changed for improvement.

TERADA 株式会社 寺田製作所
TERADA SEISAKUSHO CO.,LTD.

No.869-1 Ushio Shimada-shi Shizuoka-ken 428-8502 Japan
Phone : +81-547-45-5111 Fax : +81-547-45-5110
<https://www.web-terada.jp> E-mail: info@web-terada.jp

● Sales agent

