

Truck container

Implemented transportation which doesn't damage tea, possible because professional tea plant manufacturers. Standard when using container type riding harvester.

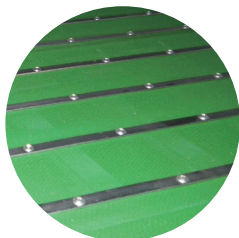

Highly durable resin net is used.



※Image is TCB-35

Features

- Discharging door can be opened to large horizontal position and can be opened & closed from either side.
- As the unloading method, highly durable resin net conveyor is used and won't damage tea leaves, it is lighter and storage volume has increased comparing to steel plate.
- Since there is no pushing plate, there won't be tea leaf jamming to the machine and won't take time to return the pushing plate.
- Open/close roof door is standard attachment to prevent tea leaf spilling and to prevent direct sunlight when transporting.

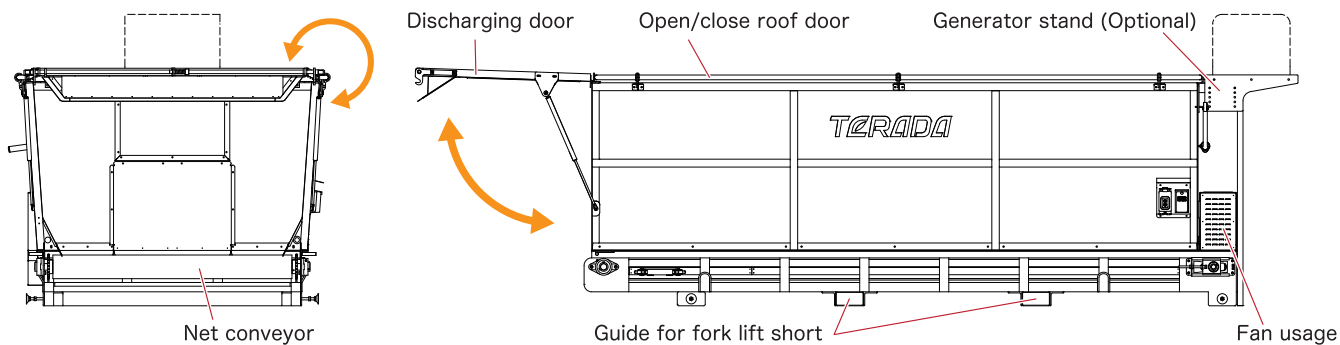

■ Specifications

Type	Length mm	Width mm	Height mm	Power		Body weight kg	Fresh leaves stock amount kg
				Net kW	Fan kW		
TCB-27	2,700	1,690	1,200	0.2 x 1	—	430	220~440
TCB-30	3,000	1,690	1,200	0.2 x 1	—	480	260~520
TCB-35	3,500	1,690	1,200	0.2 x 1	—	500	300~600
TCB-27F	2,700	1,690	1,200	0.2 x 1	0.4 x 1	490	220~440
TCB-30F	3,000	1,690	1,200	0.2 x 1	0.4 x 1	540	260~520
TCB-35F	3,500	1,690	1,200	0.2 x 1	0.4 x 1	560	300~600

※TCB-27, 27F are for 1t truck, 30, 30F, 35, 35F are for 2t truck.

※Part of the specifications might be changed for improvement.

TERADA 株式会社 寺田製作所
TERADA SEISAKUSHO CO.,LTD.

No.869-1 Ushio Shimada-shi Shizuoka-ken 428-8502 Japan
Phone : +81-547-45-5111 Fax : +81-547-45-5110
<https://www.web-terada.jp> E-mail: info@web-terada.jp

● Sales agent

